

## THE IMPACT OF SHADING IN THE PERFORMANCE OF THREE DIFFERENT SOLAR PV SYSTEMS

Jose Francisco Contero<sup>1,2</sup>, João Gomes<sup>1</sup>, Mattias Gustafsson<sup>1</sup> and Björn Karlsson<sup>1</sup>

<sup>1</sup> University of Gävle (Sweden)

<sup>2</sup> University of Zaragoza (Spain)

### Abstract

Partial shading decreases the performance of PV modules due to the series connection between the solar cells. In the recent years, several new technologies have emerged within the photovoltaics field to mitigate the effect of shading in the performance of the PV modules. For an accurate assessment of the performance of these devices, it is required to evaluate them comparatively in different circumstances.

Three systems with six series-connected PV modules (each containing 60 cells) have been installed at the University of Gävle. System One comprises a string inverter system with 6 PV modules; System Two features a DC-DC optimizer per panel and a string inverter; System Three incorporates three micro inverters for six modules.

A major conclusion of this study was that under partial shading of one (or more) modules both System Two (DC-DC optimizers) and System Three (micro inverters) perform considerably better than System One (string inverter), as long as the  $I_{mpp}$  of the shadowed module is lower than the  $I_{mpp}$  of the unshaded string. It is also important that the  $V_{mpp}$  in the shaded module is higher than the lowest allowed voltage of the DC-DC optimizer or module inverter. The economic implications of the usage of these devices were also analyzed.

Keywords: Shading; PV-cells, DC-DC, inverter, installation,  $I_{mpp}$ ,  $V_{mpp}$ ,  $P_{max}$

---

### 1. Introduction

It is well known that partial shading decreases the performance of PV modules due to the series connection between solar cells in a string. In the recent years, several new technologies and devices have emerged within the photovoltaics field to mitigate the effect of shading in the performance of the PV modules. In order to make an accurate assessment about how such devices affect the overall efficiency of the PV-systems, it is necessary to evaluate them comparatively.

#### 1.1. A standard PV system

The investigated modules have 72 series connected cells divided into 6 columns and 12 rows. There are three by-pass diodes connected between column 1 and column 2, column 3 and column 4 and between column 5 and column 6. This means that each diode is connected in parallel with 24 cells.

#### 1.2. How shading affects PV

There are several reasons that can lead to the reduction of produced power on PV panels such as manufacturing defects, degradation of cells, high solar cell temperatures, or partial shading (Stuart R. Wenham, 2012). This project has been focused on the significant decrease of power that can be caused by shading.

A cell can be seen as a combination of a current generator and a diode. Current is generated in the reverse direction of the diode. If a cell is partially shaded, it will produce less current than a cell that is fully illuminated. Voltage is practically not affected by the level of illumination, as long as a minimal level is present. During partial shading of one cell of a string, the shaded cell will not be able to generate as much current as the remaining cells of the string. Since the photo current flows in the reverse direction of the diode the unshaded cells cannot force current through the shaded cell. This means the shaded cell will limit the output of all cells in that string. Since cells are normally series connected in a string in order to raise module voltage, this causes a significant power reduction. However, if a by-pass diode is connected over the cell this will allow the surplus current to pass through the diode permitting the unshaded solar cells of the string to produce current unrestrained by the low current production caused by the shaded solar cell.

## 2. Method

The effect of shading was evaluated by controlled shading of different cells in a string of six modules.

### 2.1 The four PV installations at Gävle University

At the University of Gävle, there are four different solar systems installed. This paper is focused on the three PV systems that are shown in the picture below. Each of these three systems has 6 EOPLLY 125M/72 200 W monocrystalline modules with 72 cells and 3 bypass diodes per module (3 circuits of 24 cells per panel). There are 18 PV modules in total.



Figure 1. Systems 1, 2 and 3 at University of Gävle

#### 2.2.1 The PV panels

The electrical specifications are shown in the table below. Each panel measures 1580x808 mm.

Table 1 Electrical specifications of the modules (Energy, n.d.)

Open circuit Voltage Voc	45.73 V	Measured at STC: 25°C, 1000 $\frac{W}{m^2}$
Rated Voltage Vmpp	37.00 V	
Short Circuit Current Isc	5.589 A	
Maximum Power	200 W	
Operating Temperature	-40°C to 85°C	
Cell Efficiency	15.67%	
Module Area	1580mm x 808mm	

#### 2.2.2 System description and schematics

- **System One:** Comprises six standard PV modules series connected to one central inverter. The string inverter contains a Maximum Power Point Tracker (MPPT) that finds out the maximum power voltage and maximum power current (Vmp and Imp) by a trial and error algorithm for the PV array. A schematic drawing can be observed on the following picture:

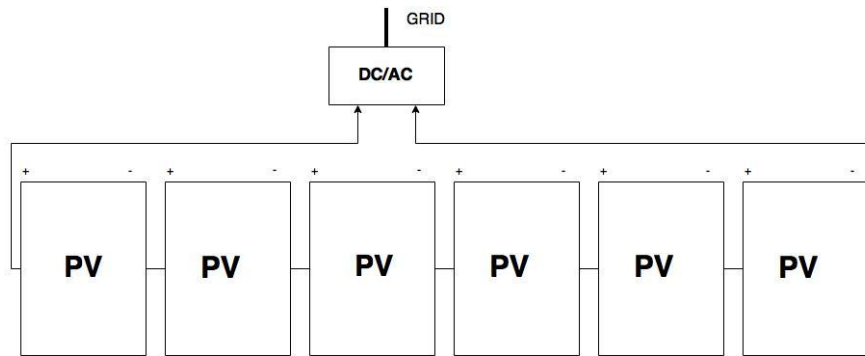

Figure 2. Schematics of System 1 (String inverter)

It is important to mention that this central inverter has a maximum DC voltage of 400V and the range of the MPP tracking in the inverter is between 100V to 320V.

- **System Two:** Comprises of the same six standard PV modules and the same string inverter as system 1. However, on this system each panel has a DC-DC optimizer. Since the output from an array of PV panels is limited by the weakest producing panel, a good solution to obtain the maximum output is to install DC-DC optimizers. They basically work as an individual MPPT for each PV panel. The DC-DC optimizers are series connected and the string inverter collects the output from the optimizers. The following figure describes how the system is connected:

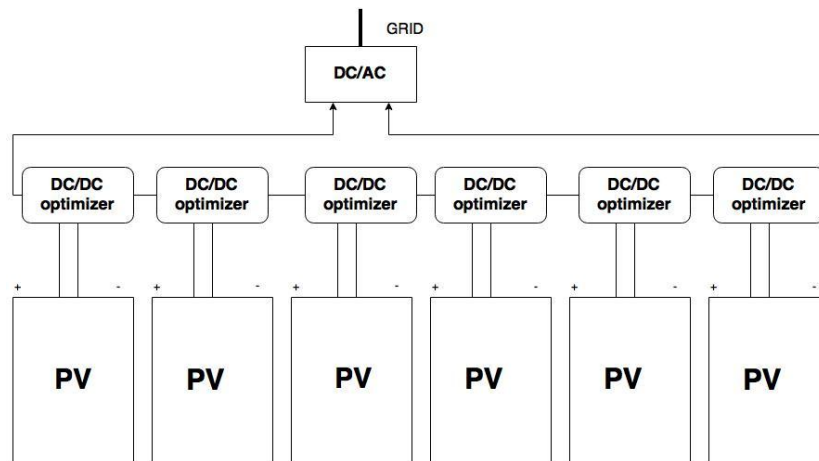

Figure 3. Schematics of System 2 (String inverter with additional DC/DC optimizers)

The following table describes the electrical specifications of the DC-DC optimizers:

Table 2. Electrical specifications for the optimizer (Tigo Eenergy, 2012)

Maximum power	375 W
Maximum Voc	52 V
V <sub>mpp</sub> range	16-48 V
Maximum Imp	9.5 A
Maximum Isc	10 A

It is important to mention that the optimizers include a function that allows the users to monitor the power as well as the voltage and current outputs during the day on the manufacturers' web page.

- **System Three:** Comprises three micro inverters for six modules, resulting in one micro inverter with a MPPT built-in for each two PV panels connected in parallel between themselves. The three inverters are connected to the grid like the above system. The following picture explains how the system is installed:

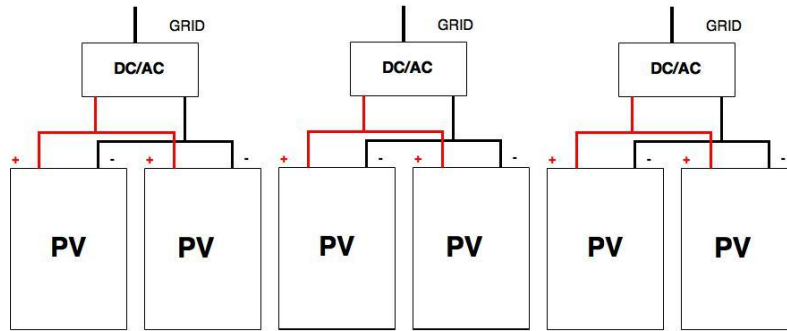

Figure 4. Schematic of system 3 (Micro inverters)

The electrical features of the micro inverters are:

Table 3. Electrical specifications of one micro inverter (Anon., n.d.)

Maximum PV power	250 W
Maximum $V_{OC}$	45 V
$V_{mp}$ range	20-40 V
Maximum $I_{SC}$	10 A

- **System four:** This system was installed slightly above the location of system one, two and three at the University of Gävle. This system consists of nine thin film modules that were only utilized as reference in order to compare the output at the same irradiance level when the remaining systems were shaded.



Figure 5. System 4 (Thin film modules)

### 2.2.3 Components of the Systems

In order to compare the different prices of the systems that are going to be investigated, its components need to be enumerated. The table below describes each system:

Table 4. Systems components

SYSTEM	COMPONENTS
System 1	6 PV modules + 1 String Inverter
System 2	6 PV modules + 1 Maximizer Management Unit + 1 Optimizer Energy Gateway + 1 Inverter (Tigo Eenergy, 2012)
System 3	3 Micro Inverters + 6 PV Modules

### 2.3 Testing Procedure

In order to know how the different systems work under shading, the performance was monitored during different shading configurations. Two different procedures have been carried out:

- **Procedure 1:** System 1 was measured with the help of a solar sensor and an IV tracer which provided the IV curves. System 2 was evaluated thanks to the website of the Tigo optimizers which gave us the voltage, current and power output. Both of these systems were always evaluated with a solar irradiance

exceeding  $750\text{W}/\text{m}^2$ . None of these procedures was available for system 3. These measurements were taken under 4 cases:

1. No shading.
2. One cell covered in one module in each system.
3. Two cells covered in different circuits in one module for all systems.
4. Three cells covered in different circuits in one module per system.

• **Procedure 2:** A data logger was collecting the power output of the three systems continuously. This data was used in a comparative analysis. Since there was no permanent pyranometer installed on site, system 4 was used as a solar radiation reference allowing us to conclude that all analyzed cases always took place during sunny days with a solar radiation exceeding  $600\text{W}/\text{m}^2$ . The measurements were performed under 5 different cases:

1. No shading.
2. One cell shaded in one module in each system.
3. Two cells shaded in different circuits in one module for both systems.
4. Three cells shaded in different circuits in one module per system
5. 30% of a row shaded in one module per system

The following figures illustrate how the modules were shaded

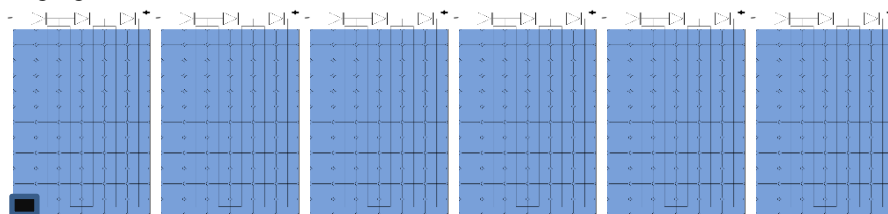

Figure 6 Case 1: No shading

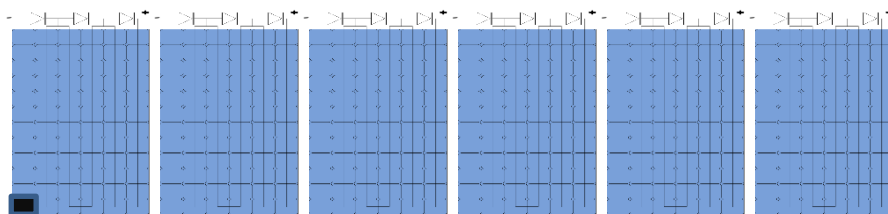

Figure 7 Case 2: One cell shaded

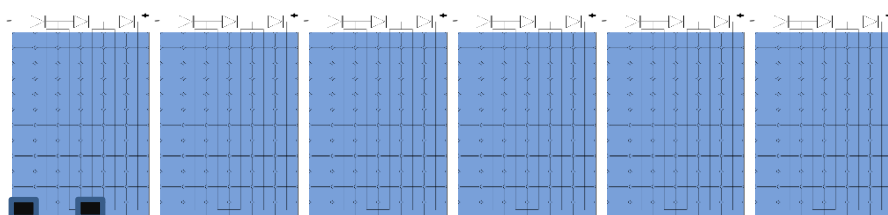

Figure 8 Case 3: Two cells shaded

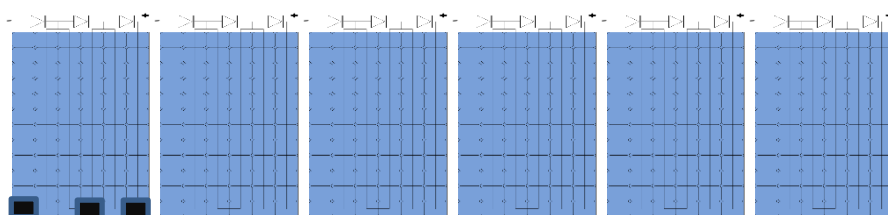

Figure 9 Case 4: Three cells shaded

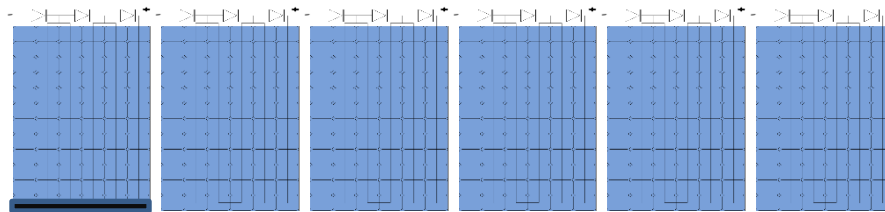

Figure 10 Case 5: 30% of a row shaded

### Measurements Limitations

In order to avoid the influence of clouds, the analysis of measured data were limited to sunny days around solar noon. Only days with high output from the modules were considered. In procedure 2, the system with thin film modules were used as a reference, instead of a pyranometer.

## 3. Results

### 3.1 Procedure 1

An IV tracer was used to measure the IV curves for system 1 for each case above. For system 2, the optimizer's webpage showed the power output of the system. A solar sensor was used in order to be able to compare the results between each case and each system. Since the module current is proportional to the irradiance on the module (Alberto Dolara, 2013), it was possible to normalize the obtained results to the irradiance level of 1000 W/m<sup>2</sup>, as shown in the following table:

Table 5. Comparison between the power output for systems 1 and 2 normalized to the same irradiation level of 1000W/m<sup>2</sup>

28/05/2015	Irradiation level [W/m <sup>2</sup> ]	System 1			System 2	
		Normalized Power [W]	Power relative to no shading (in %)	V <sub>mpp</sub> [V]	Normalized Power [W]	Power relative to no shading (in %)
No shading Case 1	762	1094	100.0	198	1089	100.0
1 cell shaded Case 2	815	1021	93.3	185	1034	95.1
2 cells shaded Case 3	877	948	86.6	171	887	81.6
3 cells shaded Case 4	1040	887	81.1	167	909	83.6

### 3.2 Procedure 2

The output during different time periods has been analyzed in order to get a comparison between the three systems which was not possible to do using procedure 1. In order to avoid influence of clouds, a careful choice

of the time periods when the output was high was made. The next graph shows the power output for the reference day with no shading based on a 10 minute resolution.

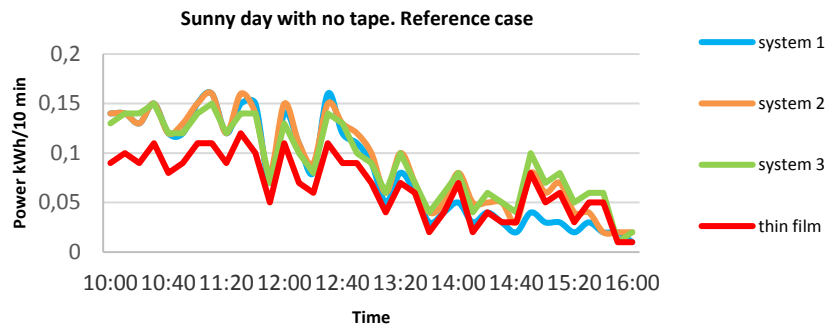

Figure 11. Power during the reference day with no shading

The following figures show the power during time periods with high power under 3 different shading cases:

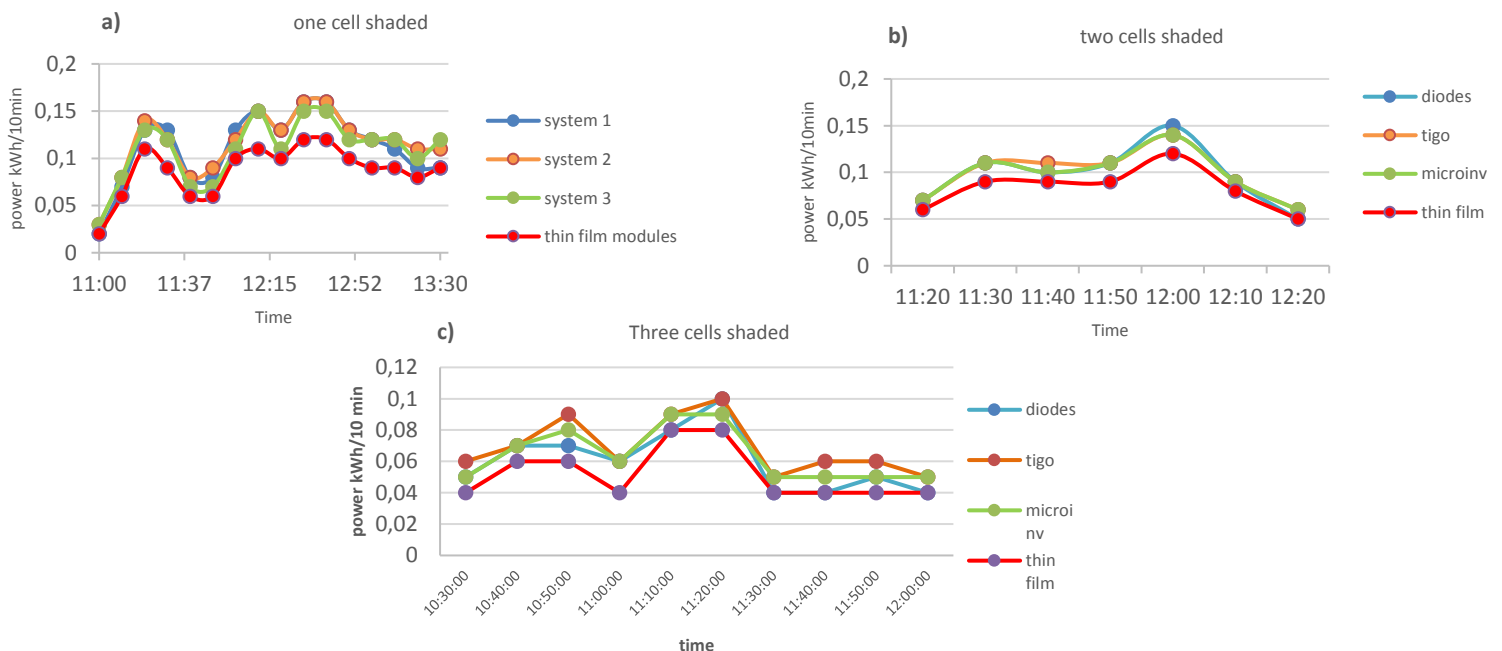

Figure 12. Power output for the cases: a) Case 2, One cell shaded, b) Case 3, Two cells shaded, c) Case 4, Three cells shaded

The following tables show the output values for each case and system. The column “percentage relative to the reference case” shows us the performance drop suffered by each system under different shading conditions. The thin film modules (system 4) were never shaded.

Table 6. Panel output in kWh during 150 minutes for the case of one cell shaded in one string

ONE CELL SHADED	150 min output [kWh]			
	Reference (No tape)	Measurement	Normalized Value	Power relative to no shading (in %)
From 11.00 to 13.30 (150 minutes)				
System 1	1,80	1,78	1,72	95,6
System 2	1,89	1,85	1,78	94,2
System 3	1,76	1,75	1,69	96,5
Thin film system (reference)	1,35	1,40	1,35	100

Table 7. Panel output in kWh during 60 min for the case of two cells shaded in two different strings

<b>TWO CELLS SHADED</b>	<b>60 min output [kWh]</b>			
<b>From 11.20 to 12.20</b>	<b>Reference (No tape)</b>	<b>Measurement</b>	<b>Normalized Value</b>	<b>Power relative to no shading (in %)</b>
<b>System 1</b>	0.82	0.64	0.71	<b>86.5</b>
<b>System 2</b>	0.85	0.64	0.71	<b>83.5</b>
<b>System 3</b>	0.78	0.63	0.70	<b>89.7</b>
<b>Thin film system (reference)</b>	0.60	0.54	0.60	<b>100</b>

Table 8 90 min output. Case of three cells shaded in the three different strings

<b>THREE CELLS SHADED</b>	<b>90 min output [kWh]</b>			
<b>From 10.30 to 12.00</b>	<b>Reference (No tape)</b>	<b>Measurement</b>	<b>Normalized Value</b>	<b>Power relative to no shading (in %)</b>
<b>System 1</b>	1.33	0.6	1.12	<b>84.2</b>
<b>System 2</b>	1.36	0.62	1.16	<b>85.3</b>
<b>System 3</b>	1.28	0.59	1.10	<b>85.9</b>
<b>Thin film system (reference)</b>	0.97	0.52	0.97	<b>100</b>

As it can be observed in the following table, the daily output of the thin films system remains stable. This is because the measured days (the reference and the studied cases) were sunny with no clouds. Therefore, the output of the different systems in the different cases is comparable.

Table 9. Daily output with a tape covering 30% of a row in one module

<b>30% of a row shaded</b>	<b>Daily output [kWh]</b>			
<b>Case</b>	<b>System 1</b>	<b>System 2</b>	<b>System 3</b>	<b>Thin film system</b>
<b>No tape (no shading)</b>	5.9	6.0	6.2	4
<b>Tape 30% row covered</b>	4.9	5.6	5.8	4
<b>Comparison to “no tape case”</b>	83.2%	93.7%	94.6%	100%

The following table summarizes the comparison results obtained:

Table 10. Comparison between the three systems during different shading configurations

	<b>% of the power relative to no tape</b>		
	<b>System 1</b>	<b>System 2</b>	<b>System 3</b>
<b>No tape (no shading)</b>	100	100	100
<b>Tape on one cell</b>	95.6	94.2	96.5
<b>Tape on two cells</b>	86.5	83.5	89.7
<b>Tape on three cells</b>	84.2	85.3	85.9
<b>Tape covers 30% of a row</b>	83.2	93.7	94.6



### 3.3 Summary of both procedures and comparison with theoretical results:

The following table summarizes the experimental results, the relative power decrease, and compares it with the theoretically expected results.

**Table 11 Percentage of the power relative to no shading. Comparison Theoretical Vs Experimental.**

	Experimental results					Theoretical power		
	Power relative to no shading (in %)					relative to no shading case (in %)		
	System 1		System 2		System 3	System 1	System 2	System 3
	Procedure 1	Procedure 2	Procedure 1	Procedure 2	Procedure 2			
No shading	100	100	100	100	100	100	100	100
One cell shaded	93.3	95.6	95.1	94.2	96.5	94,5	94,5	94,5
Two cells shaded	86.6	86.5	81.6	83.5	89.7	88,8	83,3	88,8
Three cells shaded	81.1	84.2	83.6	85.3	85.9	83,3	83,3	83,3
30% of a row shaded	---	83.2	---	93.7	94.6	83,3	95	95

### 3.4 System costs

The performance of PV modules connected to different shading mitigation systems has been shown in the above tables. However, this analysis would not be complete without looking into the costs.

This way, the investment cost for each system has been calculated. The following tables show the price of each component of the three systems installed at Gävle University.

**Table 12. Costs of the devices**

DEVICE	PRICE	PRICE [SEK]
Inverter	450€ (direct, n.d.)	5784
Optimizer Maximizer	111\$ (Solar, 2015)	903
Optimizer Energy Gateway	113\$ (Solar, s.f.)	918
Optimizer Energy Maximizer Management Unit	343\$ (direct, s.f.)	2780
Micro inverter	249€ (Anon., n.d.)	2345
PV modules	3720€ (Gomes et al., 2014)	39466

**Table 13 System Cost**

System	Price [SEK]	Added cost
System 1	18 330	0%
System 2	27 446	50%
System 3	19 581	7%

#### 4. Discussion and Conclusions

The influence of shading in solar panels is difficult to measure since both power output and the energy collected are strongly dependent on factors like the weather, time of the year, latitude and others.

Table 5 shows the decrease in  $V_{mpp}$  for each shading case of procedure 1. The current produced by the panel, after normalization to the solar radiation, remained fairly stable and thus was not included in table 5. Therefore, in the evaluated cases, the power decrease correlates very well with the voltage decrease.

In system 1 (the string inverter), when one cell is shaded, the MPP tracker finds the point that leads to the highest power production in all the series connected PV modules, which means that the five modules are working at maximum power while the shaded module is working only at 2/3 of its maximum power. This means that the maximum current possible will pass through the six panels and one bypass diode will be activated to bypass one string. The theoretical percentage of power collected from the six panels will be 95% which corresponds to 5.67 out of six modules working at full power. The data collected from the measurements in procedure two supports the above statement. Table 6 shows the same 95% percentage of power production in all systems. Likewise, system 2 (with the DC-DC optimizers) with one cell shaded shows a similar power reduction (from 100% to 95%), as shown in table 5. This means five optimizers will collect the maximum power output from five unshaded modules while the shaded one will produce only 2/3 of its maximum power output. Finally, system 3 (parallel connected micro inverters) also shows a 5% power reduction. When one cell is shaded the DC-DC optimizer and the microverter will not increase the power and all systems will produce the same power.

In the case of two cells shaded, it can be observed that in system 1, the shaded panel only produces 1/3 of the power which corresponds to two strings producing no power. In this case, the theoretical power output is about 88% of the power collected with no shading, since 5.33 out of 6 modules are working. However, using procedure 1, it can be seen that the optimizer collects slightly lower output, about the 83% of the output collected from the unshaded case. This is shown by optimizer's webpage (procedure 1) in figure 10 where it is visible that one module (in black) is basically not working:



**Figure 10. Power in Wp from each panel of system 2, in the case where two cells shaded. Each square represents the PV panel and the number inside is its power output in W.**

This is a result of the limited  $V_{mpp}$  range of the optimizers being between 16-48V. If two strings in one module are shaded, the maximum voltage output is 1/3 of the PV module voltage (about 12V) which is below 16V, the minimum operating range of the optimizers. Hence the optimizer will go to a point in the IV curve where the voltage is bigger than 16 V and consequently sacrifice the current output, collecting almost no power from the PV module like shown in figure 10. It was expected that system 3 (with the micro inverters) would have the same problem since the  $V_{mpp}$  range is between 20-40V and the expected voltage was 12V. However, looking at table 7, the output obtained is about 90% of the output with no shading in the system which means that 5.33 out of 6 modules are working. This is probably due to the fact that the total voltage of the two mismatched parallel modules is between the  $V_{mpp}$  range of the MPP tracker of the micro-inverter.

In the case where three cells are shaded in each string of one module, all of them behave in the same way; Five module produce at full power and the shaded module is not working. This can be observed in table 8.

Finally, in case 5 (where a tape was covering the 30% of the module), it can be observed that the system 1 produces less output than the other two systems. In this case, the MPP tracker of system 1 has two options: to get the power output with a current about 70% of the total generated or collect the power output with five modules working while the bypass diodes of the shadowed one are working. The MPP tracker in the string inverter will take the last option since it produces more power.

This way, the main conclusions from this paper are:

- 1) If the shaded module gives full current at MPP then optimizers and the micro inverters will not increase the output. The module gives full current, if one of the three circuits in the module are not shaded.
- 2) The  $V_{mpp}$  range of the optimizers and inverters are important. If the  $V_{mpp}$  is out of range then the module will give either no or a low output.
- 3) The optimizers and the micro inverters will increase the output if the shaded module gives lower current than the non-shaded modules. This occurs under partial shading of all circuits in one (or more) modules. In this situation both System two (DC-DC optimizers) and System Three (micro inverters) perform considerably better than System One (string or central inverter), as long as the  $I_{mpp}$  of the shadowed module is lower than the  $I_{mpp}$  of the string. It is also important that the  $V_{mpp}$  in the shaded module is higher than the lowest allowed voltage of the DC-DC optimizer or module inverter.
- 4) There is a good agreement between the experimental results and the theoretically expected results for all cases.

From an economic perspective, considering the impact of shading, since system 2 (DC-DC optimizer) does not collect more energy than system 3 and it is 50% more expensive, it should not be selected as an option. System 1 (string inverter) is the cheapest and for this reason, it is preferable in all situations when one can be certain that there will be no shading. When one is uncertain if shading will occur, the extra 7% cost (difference between system 1 and system 3 with micro inverters) will probably be justified since the increase in annual energy produced should be superior to 7%.

## **5. Acknowledgements**

The authors would like to thank the financial support given by the PV Applied Research and Development programs (SolEl) from the Swedish Energy Agency and Swedish industries through the Energy Research Institute.

## 6. References

Alberto Dolara, G. C. L. S. L. G. M., 2013. Experimental investigation of partial shading scenarios on PV. *Energy*, Volume 55, pp. 466-475.

Anon., n.d. *PVshop.eu*. [Online]

Available at: <http://pvshop.eu/PV-Solar-Micro-Inverter-250W-AEConversion-INV250-45EU.html>  
[Accessed 17 6 2015].

direct, B. P., n.d. *Buy PV direct*. [Online]

Available at: [http://www.buypvdirect.co.uk/SMA\\_SunnyBoy\\_SB1200\\_Solar\\_Inverter](http://www.buypvdirect.co.uk/SMA_SunnyBoy_SB1200_Solar_Inverter)  
[Accessed 17 June 2015].

direct, e., n.d. *eco direct*. [Online]

Available at: <http://www.ecodirect.com/Tigo-MU-ESW-p/tigo-mu-esw.htm>  
[Accessed 17 June 2015].

Energy, E. s., n.d. *Solar Modules*. [Online]

Available at: [http://www.eopllly.com/Htdocs/Html/\\_productsModuleDetail.asp?SolarModules\\_id=22](http://www.eopllly.com/Htdocs/Html/_productsModuleDetail.asp?SolarModules_id=22)  
[Accessed 10 June 2015].

João Gomes, J. J. B. K., 2014. *Defining an annual energy output ratio between PV and solar thermal*. Aix-les-Bains, s.n.

SMA, n.d. *Sunny Boy 1200 / 1700 / 2500 / 3000*. [Online]

Available at: [http://www.el-tec.nl/include/nl/downloads/SB1200\\_3000-DEN110712W.pdf](http://www.el-tec.nl/include/nl/downloads/SB1200_3000-DEN110712W.pdf)  
[Accessed 10 June 2015].

Solar, C., 2015. [Online]

Available at: <http://www.civicsolar.com/product/tigo-energy-mm-2es50-tyco-st-dual-maximizer-w-tyco-connectors>  
[Accessed 17 June 2015].

Solar, C., n.d. *Civic Solar*. [Online]

Available at: <http://www.civicsolar.com/product/tigo-energy-mu-gtwy-extra-gateway>  
[Accessed 17 June 2015].

Stuart R. Wenham, M. A. G. M. E. W. a. R. C., 2012. *Applied photovoltaics*. New South Wales: Earthscan.

Tigo Energy, I., 2012. *Tigo energy*. [Online]

Available at: [http://www.tigoenergy.com/sites/default/files/attachments/mm-2es\\_data\\_sheet\\_1.12.2015.pdf](http://www.tigoenergy.com/sites/default/files/attachments/mm-2es_data_sheet_1.12.2015.pdf)  
[Accessed 5 6 2015].